



## Description

Reliable industrial grade Bluetooth® Low Energy beacon for industrial identify, sense and locate applications.



## Electrical specifications

### Device type

Bluetooth® Low Energy beacon, Battery powered

### Wireless interface protocol

Bluetooth® Low Energy 5.1  
NFC: ISO/IEC 14443A

### Compliance

Europe (CE), UK (UKCA), USA (FCC), Canada (IC),  
Australia/New Zealand (ACMA), South-Korea (KC),  
Japan (MIC), Ukraine (UkrSEPRO), Brazil (ANATEL)

### Operational frequency

ISM: 2402 - 2480 MHz  
NFC: 13,56 MHz

### SOC

Nordic Semiconductor NRF52832

### Memory configuration

512 kB FLASH, 64 kB RAM

### Configuration interface

Over NFC interface with Runestone™ mobile app  
(available for android mobile phones in Google  
Play store)

### Sensors\*

Built-in temperature sensor and hall switch  
Optional accelerometer

### Sensitivity / Max transmit power

-96 dBm / +4 dBm

### Read range\*\*

Up to 100 m / 330 ft.

### Battery type (total capacity)

2 x CR2477 (1900mAh) coin batteries

### Applicable surface materials

Can be attached to any surface

\* Temperature sensor is located inside the housing, which limits real time measurement of the ambient temperature.

\*\* Read ranges can vary significantly depending on the mounting surface and environment.



## Mechanical specifications

### Housing material

Polyurethan casting, black

### Enclosure IP class

IP69K

### Weight

70 g

### Tag dimensions

56,4 x 55,6 x 21 mm / 2.22 x 2.19 x 0.83 in  
(M5 size hole)

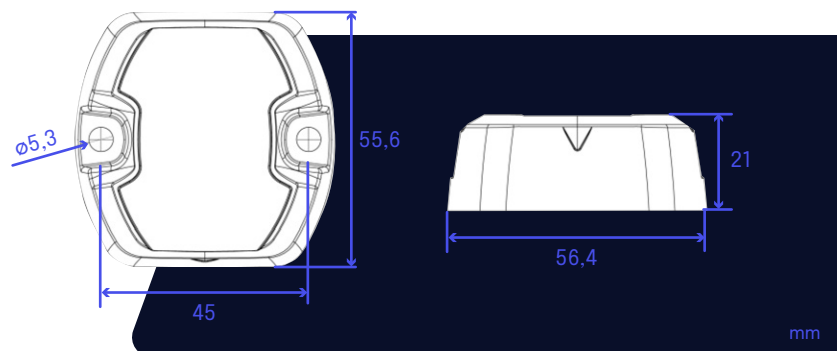

mm



## Environmental resistance

### Operating temperature

-40°C to +85°C / -40°F to +185°F

EN 60068-2-14: 2009, Test N: Change of temperature

### Vibration resistance

EN 60068-2-6: 2008, Test Fc: Vibration, 20G

EN 60068-2-27: 2009, Test Ea: Shock, 40G

### ESD immunity

±8 kV according to EN 61000-4-2 (air discharge)

±4 kV according to EN 61000-4-2 (contact discharge)

### Chemical resistance \*\*\*

No physical or performance changes in:

- 168h Motor oil exposure
- 48h Salt water (salinity 10%) exposure
- 48h Sulfuric acid (10%, pH 2) exposure
- 48h NaOH (10%, pH 13) exposure

Generally good resistance with moderate concentrations of acids, alcohols, alkalis, detergents, and cleaners. Acetone should be avoided.

### Expected lifetime\*\*\*\*

7-8 years with typical operating parameters

\*\*\*Values are the best recommendations; resistance against environmental conditions depends on the combination of all influencing factors, exposure duration and chemical concentrations. Thus, product's final suitability for certain environmental conditions is recommended to be tested. Contact Confidex for more specific information. \*\*\*\* Beacon lifetime is optimized for long term use, and is highly affected by operating mode parameters, accelerometer usage and ambient temperature. Configured TX power level and advertisement interval have influence on lifetime.



## Supported Frames



Eddystone



iBeacon



**Beontag Viking** beacon utilizes Eddystone™ open standard frame format and/or iBeacon protocol ensuring straightforward implementation on a wide range of Bluetooth® Low Energy devices.

**Beontag Viking Tough** comes with standard parameters by default. It can be factory configured with customer specific parameters to support any 3rd party system.

**Beontag Viking** can also be personalized with a custom label to ease the tag identification in the field.

### Following Eddystone™ frame types are supported:

- **Eddystone™-UID** frame broadcasts 16-byte Beacon ID composed of a 10-byte namespace and a 6-byte instance.
- **Eddystone™-URL** frame broadcasts a URL using a compressed encoding format.
- **Eddystone™-TLM** frame broadcasts telemetry information (e.g. SoC voltage and temperature).
- **iBeacon** advertise 16 bytes UUID, 2 bytes Major, and 2 bytes Minor.
- **Accelerometer** frames are proprietary advertising packets which broadcasts **Beontag Viking** acceleration statistics and activity.



## Installation instructions

### 1. Mechanical fixing - Screw

Mechanical fixing is recommended to be used in every application that includes risk for high mechanical stress or low temperature during tag fixing. Screw size M5 is to be used for fixing.

### 2. Mechanical fixing - Cable tie

Plastic or metallic cable ties can also be used for fixing **Beontag Viking Tough**. Max width of cable tie is 4 mm.

### 3. High performance acrylic adhesive

When mounting the tag with adhesive, clean and dry the surface for obtaining the maximum bond strength.



**Order information****3003959 Beontag Viking Tough, no accelerometer**

- With default configuration and no label

**3004055 Beontag Viking Tough, no acc., personalized**

- With customer specific configuration and label

**3002662 Beontag Viking Tough, with accelerometer**

- With default configuration and no label

**3003624 Beontag Viking Tough, with acc., personalized**

- With customer specific configuration and label

**3003640 Beontag Viking Tough Sample kit**

- Contains 5 pcs of item 3002662

**For other versions, additional information and technical support please contact Beontag.**

**DISCLAIMER**

THE MATERIALS, PRODUCTS AND SERVICES ARE SOLD SUBJECT TO ITS STANDARD CONDITIONS OF SALE, WHICH ARE INCLUDED IN THE APPLICABLE DISTRIBUTOR OR OTHER SALES AGREEMENT. ALTHOUGH ANY INFORMATION, RECOMMENDATIONS, OR ADVICE CONTAINED HEREIN IS GIVEN IN GOOD FAITH, BEONTAG MAKES NO WARRANTY OR GUARANTEE, EXPRESS OR IMPLIED, (i) THAT THE RESULTS DESCRIBED HEREIN WILL BE OBTAINED UNDER END-USE CONDITIONS, OR (ii) AS TO THE EFFECTIVENESS OR SAFETY OF ANY DESIGN INCORPORATING ITS PRODUCTS, MATERIALS, SERVICES, RECOMMENDATIONS OR ADVICE. EXCEPT AS PROVIDED IN BEONTAG STANDARD CONDITIONS OF SALE, BEONTAG AND ITS REPRESENTATIVES SHALL IN NO EVENT BE RESPONSIBLE FOR ANY LOSS RESULTING FROM ANY USE OF ITS MATERIALS, PRODUCTS OR SERVICES DESCRIBED HEREIN.

Each user bears full responsibility for making its own determination as to the suitability of Beontag products, materials, services, recommendations, or advice for its own particular use. Each user must identify and perform all tests and analyses necessary to assure that its finished systems incorporating Beontag products, materials, or services will be safe and suitable for use under end-use conditions. Nothing in this or any other document, nor any oral recommendation or advice, shall be deemed to alter, vary, supersede, or waive any provision of this Disclaimer, unless any such modification is specifically agreed to in a writing signed by Beontag.

**About Beontag**

From the science of graphic and label materials, RFID and wireless IoT enablers, we create solutions across the value chain to deliver digital transformation for businesses around the world.

Sustainability is at the core of what we do and we strongly believe that by substituting non-renewable materials and innovating through more sustainable and renewable products, we act as an ESG enabler for our customers' value chain.

Beontag is one of the world's leading providers of RFID and wireless IoT solutions, being present in more than 40 countries with 7 R&D centers and 2,000 employees, in constant development of technological and sustainable solutions designed to connect items, and gain efficiency and end-to-end traceability

**CONTACT US FOR  
MORE INFORMATIONS:  
[beontag.com](http://beontag.com)**

The performance of the product should always be tested in the actual application conditions. Our recommendations are based on our most current knowledge and experience and the pictures and illustrations presented in this document are for illustration purposes only. As our products are used in conditions beyond our control, we cannot assume any liability for damage caused through their use. Beontag reserves the right to change its products and services at any time without notice.

